



PRELIMINARY MX23L6414

64M-BIT MASK ROM

FEATURES

- Bit organization
 - 8Mb x 8 (byte mode)
 - 4Mb x 16 (word mode)
- Fast access time
 - Random access:90/25ns(max.)
- Page Size
 - 8 words per page
- Current
 - Operating:20mA
 - Standby:15uA(max.)
- Supply voltage
 - VCC : 2.7 ~ 3.6V
 - VCCQ : 2.7 ~ 3.6V
- Package
 - 64 ball mini BGA (10.0mm X 13.0mm, ball pitch 1.0mm)
 - 56 pin TSOP (14mm x 20mm)
- Temperature
 - 25~85° C

PIN DESCRIPTION

Symbol	Pin Function
A0~A22	Address Inputs, A0 not used in word mode
D0~D15	Data Outputs
CE0#, CE1# CE2#	Chip Enable Input
OE#	Output Enable Input
BYTE#	Word/Byte mode Selection
VCC	Power Supply Pin
VCCQ	Output VCC Pin
GND	Ground Pin
NC	No Connection

CHIP ENABLE TRUTH TABLE

CE2#	CE1#	CE0#	Device
L	L	L	Enabled
L	L	H	Disabled
L	H	L	Disabled
L	H	H	Disabled
H	L	L	Enabled
H	L	H	Enabled
H	H	L	Enabled
H	H	H	Disabled

Note: for single-chip applications, CE2#, CE1# can be strapped to GND.

PIN CONFIGURATION

56 TSOP (Normal Type)

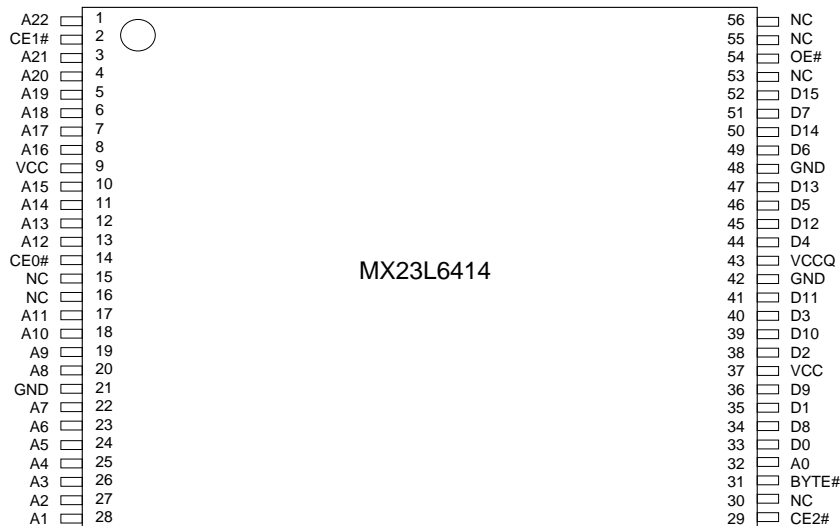

64 Mini BGA (Top View, Balls Facing Down)

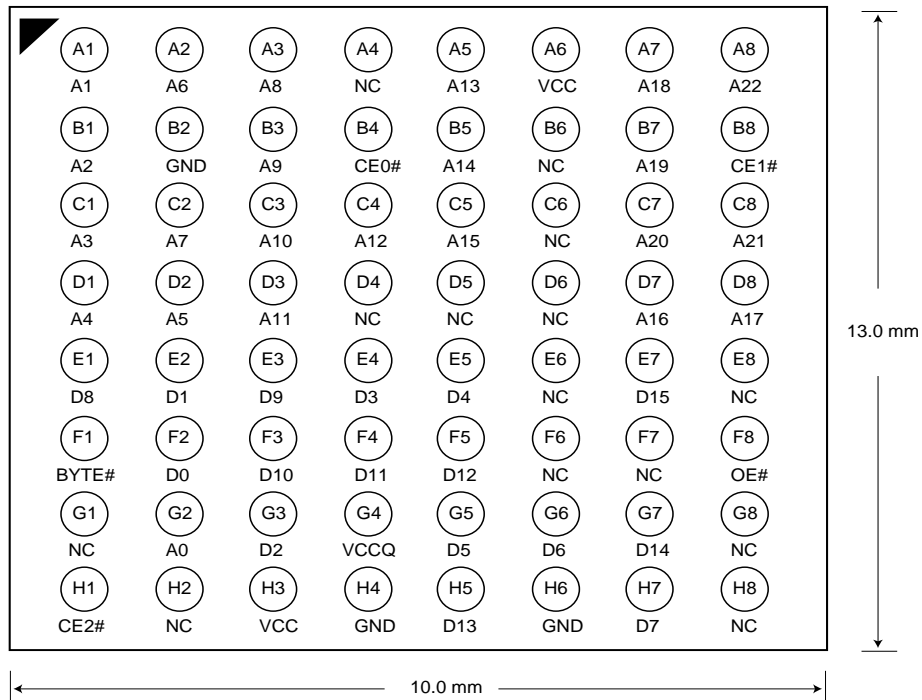

MODE SELECTION

CE#	OE#	Byte#	D0~D7	D8~D15	Power
Disabled	X	X	High Z	High Z	Stand-by
Enabled	H	X	High Z	High Z	Active
Enabled	L	L	D0~D7	High Z	Active
Enabled	L	H	D0~D7	D8~D15	Active

ORDER INFORMATION

Part No.	Speed	Package	Grade	Remark
MX23L6414TI-90	90ns	56 pin TSOP	Industrial	
MX23L6414TI-10	100ns	56 pin TSOP	Industrial	
MX23L6414TI-12	120ns	56 pin TSOP	Industrial	
MX23L6414XI-90	90ns	64 ball mini BGA	Industrial	
MX23L6414XI-10	100ns	64 ball mini BGA	Industrial	
MX23L6414XI-12	120ns	64 ball mini BGA	Industrial	
MX23L6414XI-12G	120ns	64 ball mini BGA	Industrial	Pb-free

Note: Industrial grade temperature: -25 ~ 85° C
Commercial grade temperature: 0 ~ 70° C



ABSOLUTE MAXIMUM RATINGS

Item	Symbol	Ratings
Voltage on any Pin Relative to VSS	VIN	-0.3V to 3.9V
Ambient Operating Temperature	Topr	-25° C to 85° C
Storage Temperature	Tstg	-65° C to 125° C

DC CHARACTERISTICS (Ta = -25° C ~ 85° C, VCC = 2.7V~3.6V)

Item	Symbol	MIN.	MAX.	Conditions
Output High Voltage	VOH	2.4V	-	IOH = -400uA
Output Low Voltage	VOL	-	0.4V	IOL = 1.6mA
Input High Voltage	VIH	2.2V	VCCQ+0.5V	
Input Low Voltage	VIL	-0.5V	0.8V	
Input Leakage Current	ILI	-	10uA	0V, VCC
Output Leakage Current	ILO	-10	10uA	0V, VCC
Operating Current	ICC	-	20mA	f=5MHz, CE#=VIL, OE#=VIH all output open
Standby Current (CMOS)	ISTB	-	15uA	CE#>VCC-0.2V
Input Capacitance	CIN	-	10pF	Ta = 25° C, f = 1MHZ
Output Capacitance	COUT	-	10pF	Ta = 25° C, f = 1MHZ

AC CHARACTERISTICS (Ta = -25° C ~ 85° C, VCC = 2.7V~3.6V)

Item	Symbol	23L6414-90		23L6414-10		23L6414-12	
		MIN.	MAX.	MIN.	MAX.	MIN.	MAX.
Read Cycle Time	tRC	90ns	-	100ns	-	120ns	-
Address Access Time	tAA	-	90ns	-	100ns	-	120ns
Chip Enable Access Time	tACE	-	90ns	-	100ns	-	120ns
Page Mode Access Time	tPA	-	25ns	-	25ns	-	25ns
Output Enable Time	tOE	-	25ns	-	25ns	-	25ns
Output Hold After Address	tOH	0ns	-	0ns	-	0ns	-
Output High Z Delay	tHZ	-	20ns	-	20ns	-	20ns

Note: Output high-impedance delay (tHZ) is measured from OE# or CE# going high, and this parameter guaranteed by design over the full voltage and temperature operating range - not tested.

AC Test Conditions

Input Pulse Levels	0.4V~2.4V
Input Rise and Fall Times	5ns
Input Timing Level	1.5V
Output Timing Level	1.5V
Output Load	See Figure 100pF output load capacitance

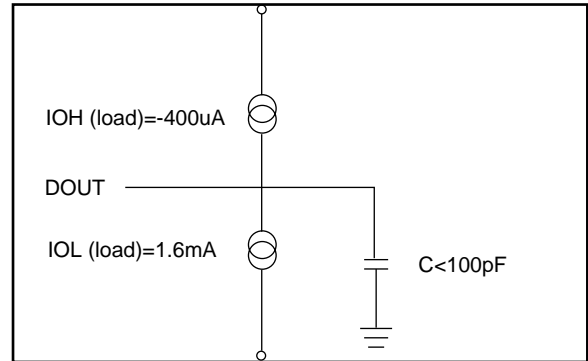

Note: No output loading is present in tester load board.
Active loading is used and under software programming control.
Output loading capacitance includes load board's and all stray capacitance.

TIMING DIAGRAM

RANDOM READ

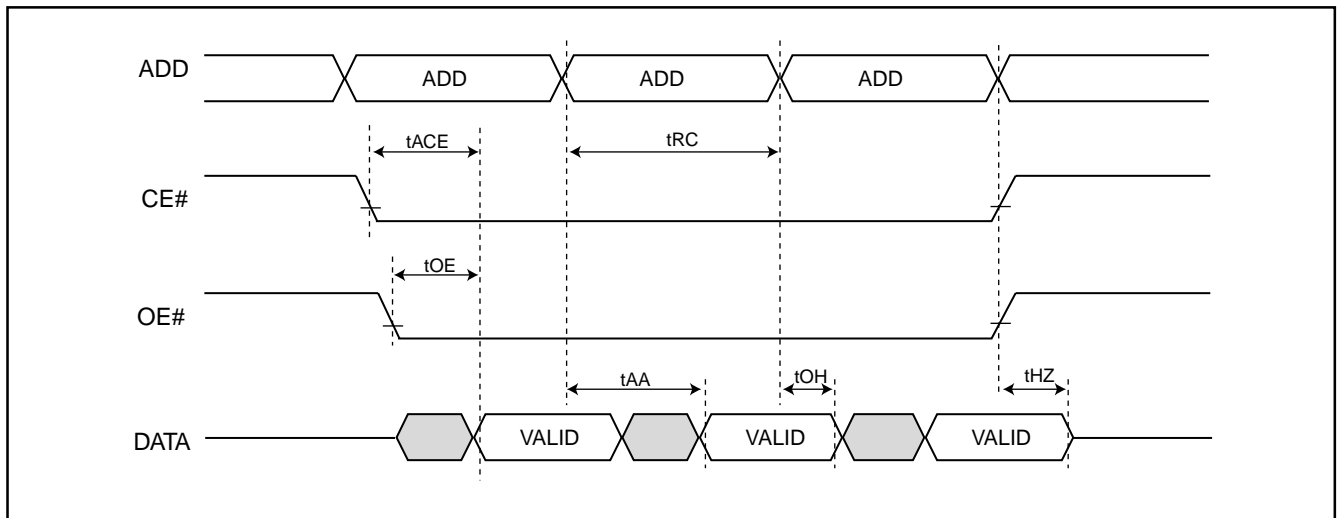

PAGE READ

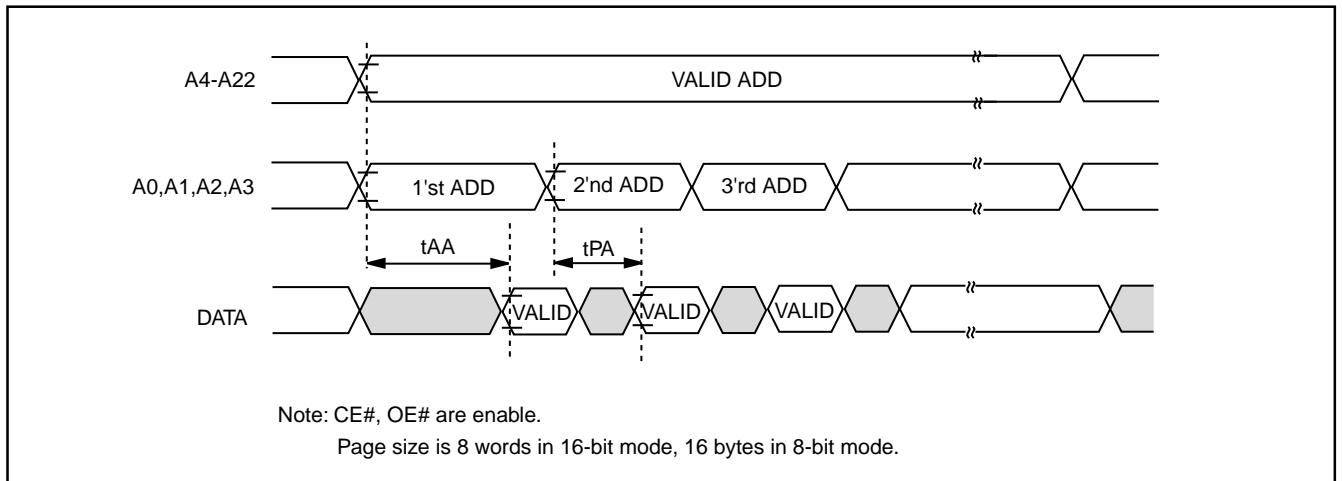



REVISION HISTORY

Revision	Description	Page	Date
1.0	1. Random access:90/35(max.)-->80/25(max.) 2. Add page size -- 8 words per page 3. Package:64 ball mini BGA(8.0mmx10.0mm)-->64ball mini BGA (10.0x13.0mm) 4. Add Order Information 5. Modify Standby Current:10uA-->15uA 6. Change heading as "RELIMINARY "	P1,3 P1 P1 P2 P1,3 P1	AUG/29/2001
1.1	1. Modify DC Characteristics--VOH:VCCQ-0.2V-->2.4V, IOH=-100uA-->-400uA, VOL:0.2V-->0.4V, IOL:100uA-->1.6mA, VIH:2.0-->2.2V 2. Modify AC Test Conditions--Input Pulse Levels:0~VCCQ-->0.4V~2.4V, P4 Input/Output Timing Level:VCCQx0.5-->1.5V, Output Load:30pF-->100pF output load capacitance	P3	SEP/10/2001
1.2	Add CE#=VIL, OE#=VIH in DC Characteristics's ICC	P3	OCT/02/2001
1.3	1. Modify fast access time:80ns-->90ns	P1~3	MAY/07/2002
1.4	1. Modify Operating Current : 40 --> 20mA	P1,3	DEC/31/2002
1.5	1. Added Pb-free package	P2	MAY/26/2005



MX23L6414

MACRONIX INTERNATIONAL Co., LTD.

Headquarters:

TEL:+886-3-578-6688

FAX:+886-3-563-2888

Europe Office :

TEL:+32-2-456-8020

FAX:+32-2-456-8021

Hong Kong Office :

TEL:+86-755-834-335-79

FAX:+86-755-834-380-78

Japan Office :

Kawasaki Office :

TEL:+81-44-246-9100

FAX:+81-44-246-9105

Osaka Office :

TEL:+81-6-4807-5460

FAX:+81-6-4807-5461

Singapore Office :

TEL:+65-6346-5505

FAX:+65-6348-8096

Taipei Office :

TEL:+886-2-2509-3300

FAX:+886-2-2509-2200

MACRONIX AMERICA, INC.

TEL:+1-408-262-8887

FAX:+1-408-262-8810

<http://www.macronix.com>
